

## ASSEMBLY INSTRUCTIONS EL-469/EL-479

### Fully Adjustable Media Storage Unit

**EL-469** – Genuine Natural Cherry Wood Veneer.

**EL-479** – Durable Metallic Grey Matte Lacquer.

7 adjustable shelves can house 252 CD's or 112 DVD's + 36 CD's combined.

Overall Dimensions: H - 44", W - 18 5/8", D - 10 1/8".

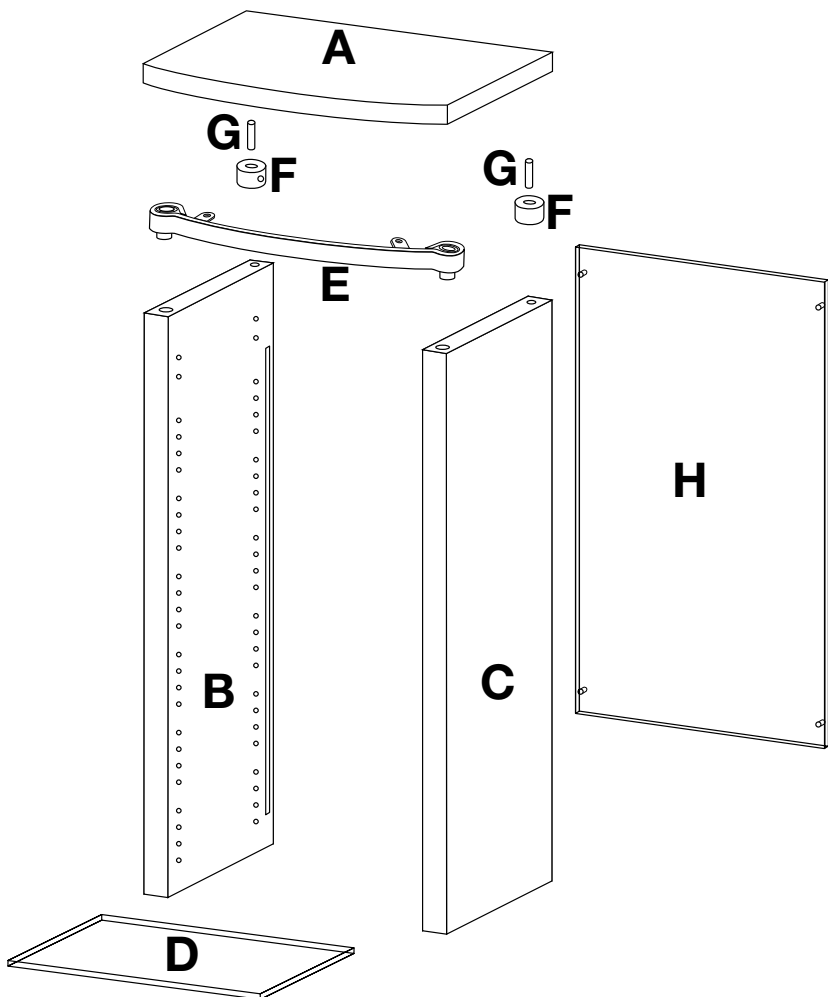

Thank you for purchasing this ELITE product. You will need the following tools:

- Regular straight blade screw driver
- Phillips head screwdriver
- Rubber or padded hammer

In order to protect the finish, we recommend working on a padded or carpeted surface.

Before discarding the box, be sure that no parts are left inside.

PLEASE NOTE: The following letters correspond to the sketches in this instruction booklet.

- A. Top Panel (1)
- B. Left Side Panel (1)\*
- C. Right Side Panel (1)\*
- D. Glass Shelf (7-identical)
- E. Front Metal Top Molding (1)
- F. Back Metal Post (2)
- G. Back Post Pins (2)
- H. Back Panel (acrylic) (1)

**\*IMPORTANT:** Make sure shelf pin holes on Side Panels B & C face inside during assembly. FRONT EDGES of Side Panels B & C do NOT have holes. Curved Molding (Front Metal Molding - E) will be inserted into Front Edge of Side Panels B & C with metal tabs facing the back of unit.

BACK EDGES of Side Panels B & C DO have holes for installation of Back Panel (H). Back Metal Posts (F) with Pins (G) will be inserted into Top Back Edges of Side Panels B & C.

### EL-469/EL-479 Hardware

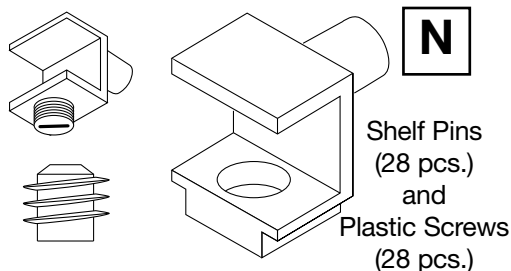
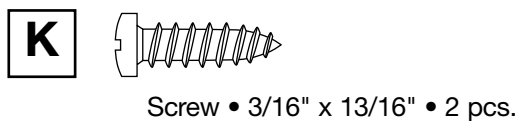
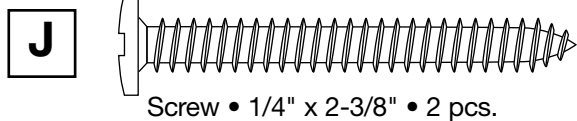

**PLASTIC SCREWS MUST BE INSTALLED INTO THE SHELF PINS**

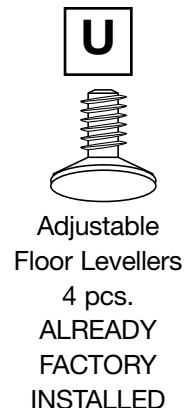
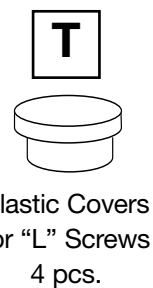
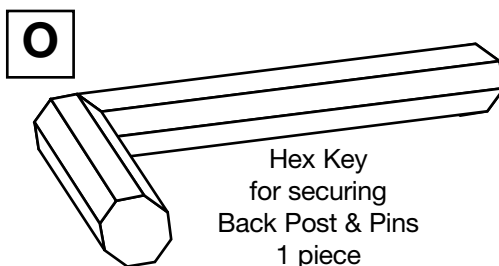

# 1 INSTALL FRONT MOLDING

**\*IMPORTANT:** Make sure shelf pin holes on Side Panels B & C face *inside* during assembly.

**FRONT EDGES** of Side Panels B & C do **NOT** have holes. Curved Molding (Front Metal Molding - E) will be inserted into Front Edge of Side Panels B & C with metal tabs facing the back of unit.

**BACK EDGES** of Side Panels B & C **DO** have holes for installation of Back Panel (H). Back Metal Posts (F) with Pins (G) will be inserted into Top Back Edges of Side Panels B & C.



Use a padded hammer or a regular hammer with a block of wood when tapping molding into place.

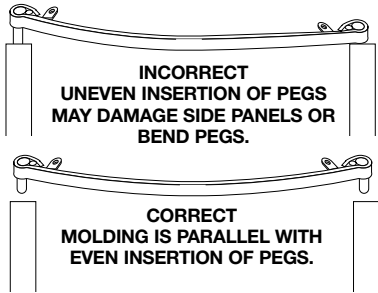

Tap left and right sides of molding alternately to make sure that molding is inserted evenly into both side panels. **Do not** fully tap in one side of molding before tapping in the opposite side. This may cause damage to side panels.

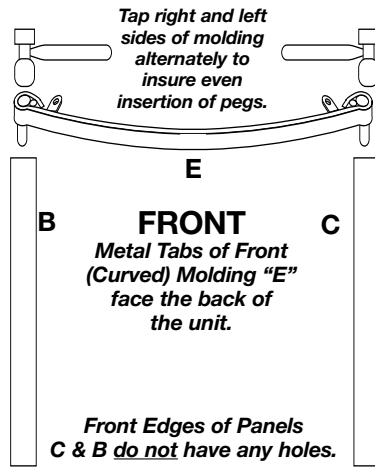
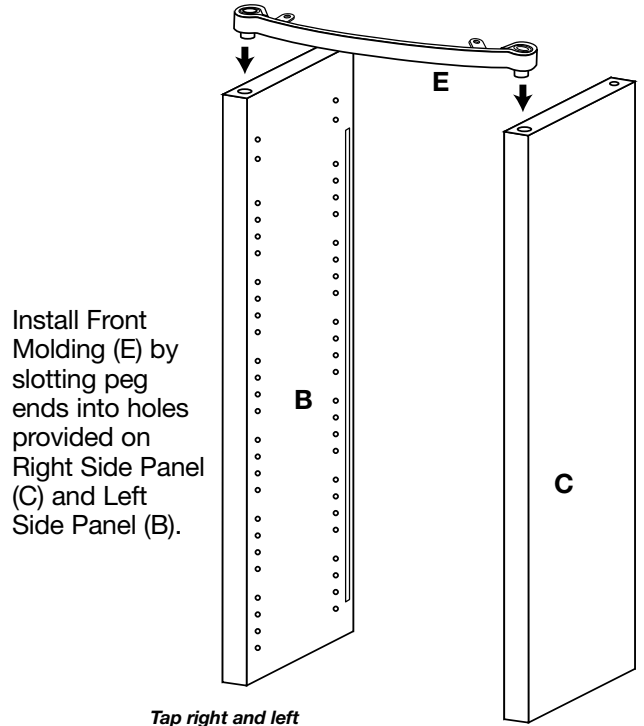

# 2 INSERT BACK PANEL

**A.** Remove protective foil from both sides of Back Panel (H).

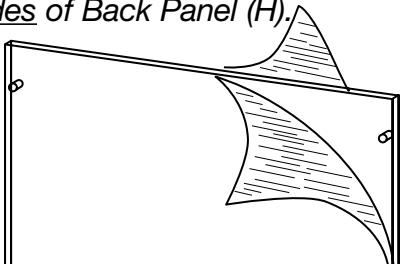

**B.** Insert Back Panel (H) into slots at back inside edges of Side Panels B and C.

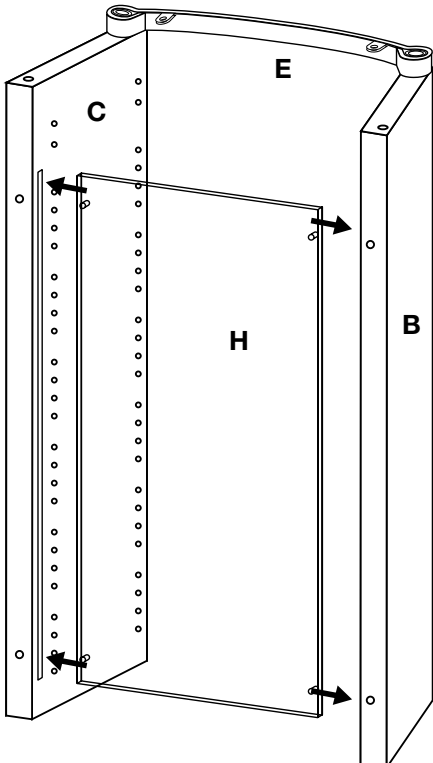

**C.** Using 4 screws (L), secure Back Panel and 2 Side Panels.

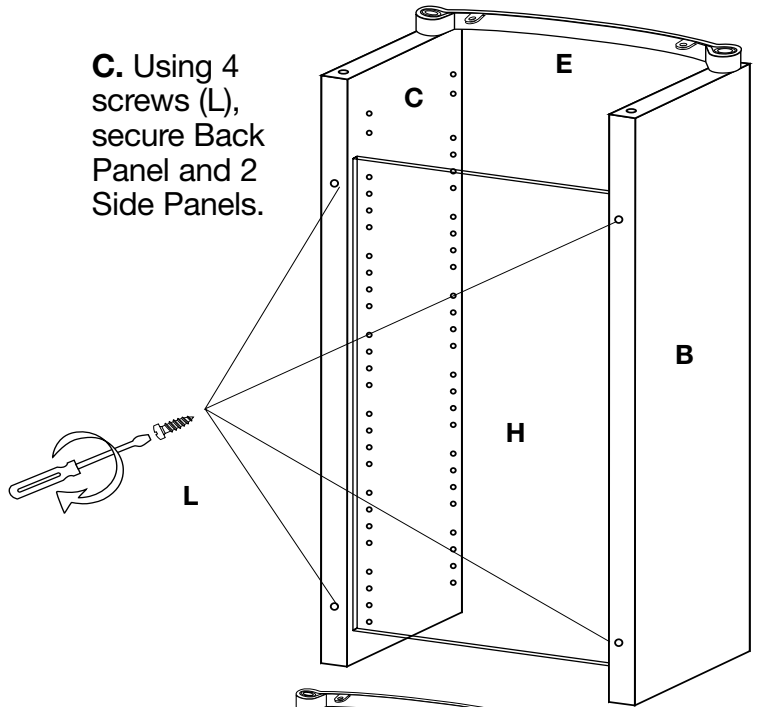

**D.** Add Plastic Covers (T) to each of the 4 screw locations.

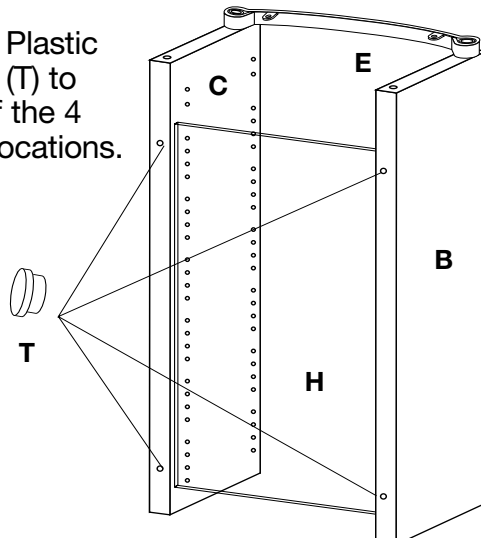

### 3 SCREW IN FRONT MOLDING

Using 2 screws (J), secure Front Metal Top Molding (E) to side panels.

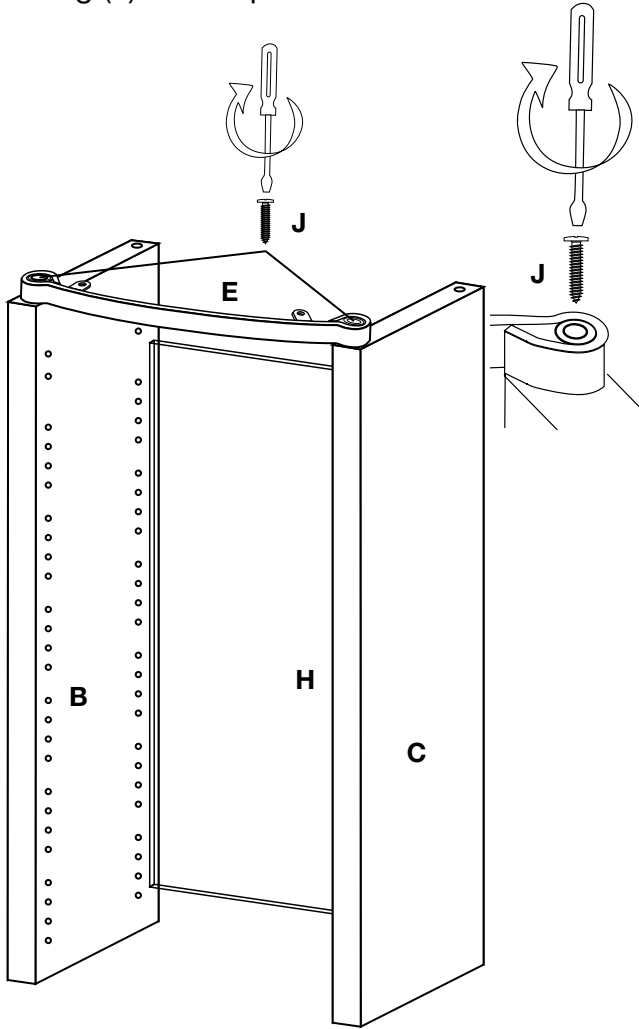

### 4 PREPARE TOP PANEL

Using 2 screws (M) attach Back Metal Posts (F) to back straight edge on underside of Top Panel (A).

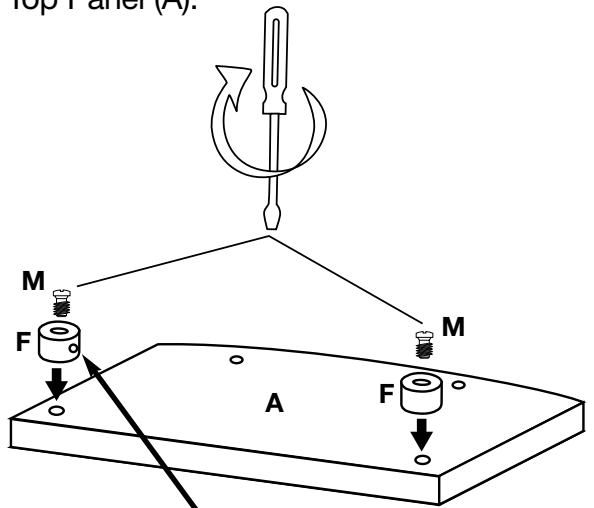

#### IMPORTANT

Be sure to position Back Metal Posts (F) so that screw holes for hex key face inside.

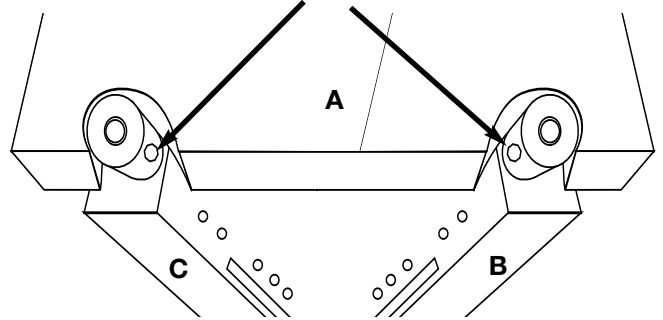

### 5 INSERT BACK POST PINS

Using a Padded Hammer, Tap in 2 Post Pins (G) at top back edges of Side Panels B and C.

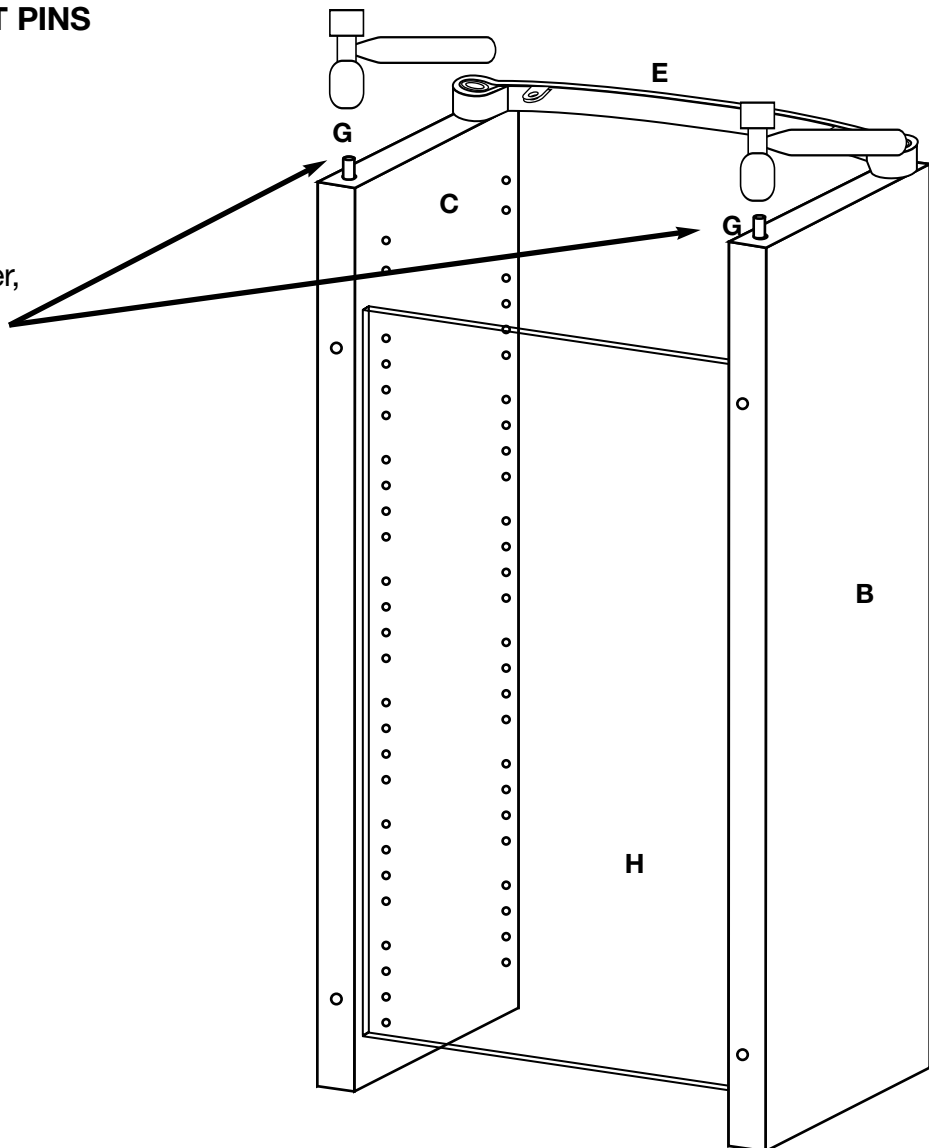

## 6 ATTACH TOP PANEL

Position Back Metal Posts of Top Panel (A) over Post Pins and align holes on underside of Top Panel (A) with metal tabs of Top Front Metal Molding (E).

Using Hex Key (O) tighten hex lock mechanisms on Back Metal Posts to secure position.

Using 2 screws (K), secure Metal Front Molding to underside of Top Panel (A).

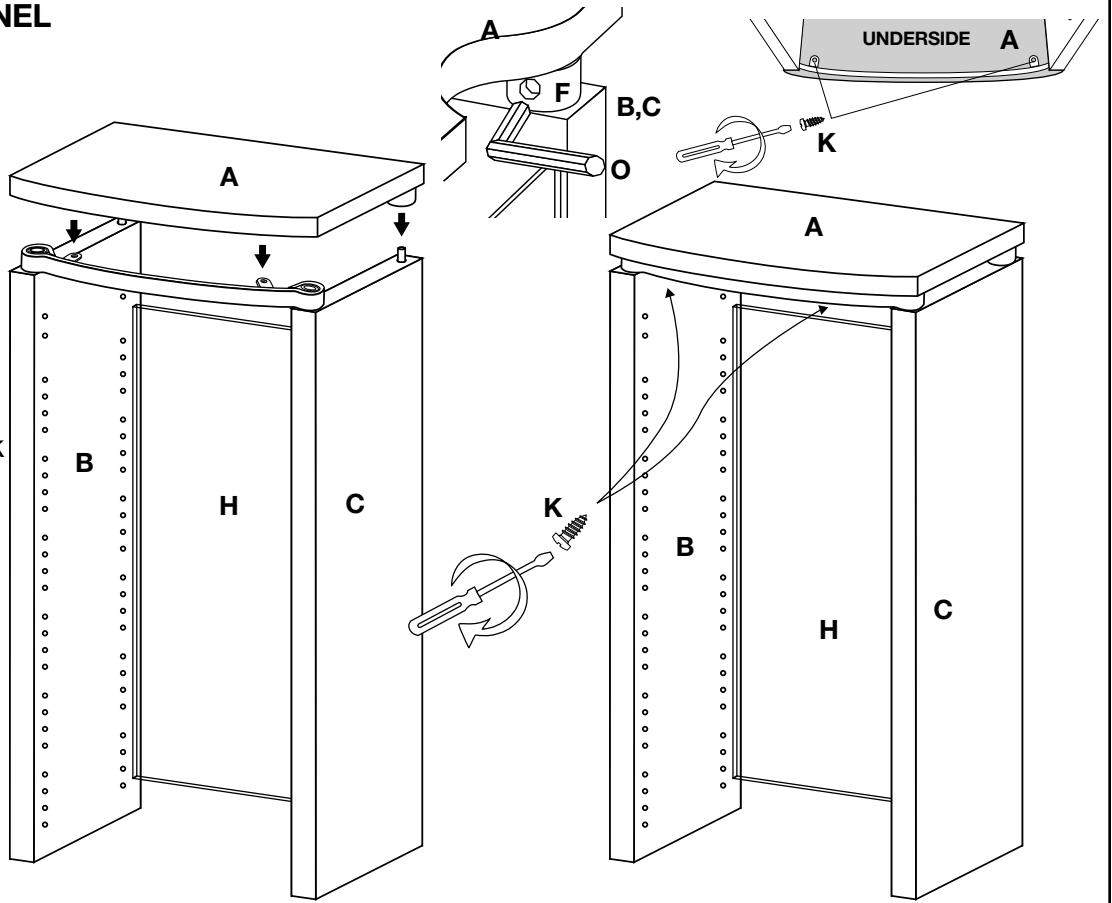

## 7 ADD GLASS SHELVES

Insert Shelf Pins (N) at desired heights on both Side Panels B and C.

**NOTE:** Before adding glass shelves, check plastic screw adjustment on ALL shelf pins to be sure glass will slide smoothly into slots from front to back.

Slide glass shelves into shelf pins. **Make sure to secure all shelves in place, using all plastic adjustment screws on undersides of shelf pins, turning them clockwise to lock.**

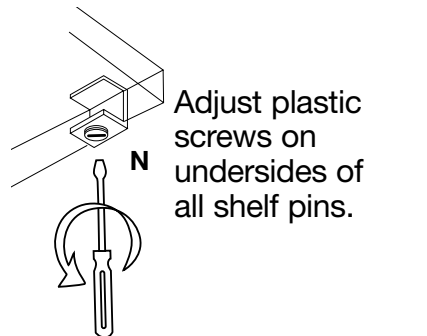

Adjust plastic screws on undersides of all shelf pins.

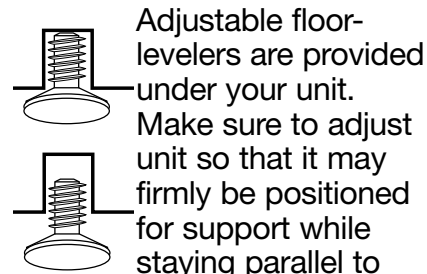

Adjustable floor-levelers are provided under your unit. Make sure to adjust unit so that it may firmly be positioned for support while staying parallel to ground. Avoid any forward tilt which may cause TV to lean off balance. Do not to over-extend levelers beyond their supporting housing. They need to firmly remain within the grip of their threaded bushings.

Maximum extension = 1/4".

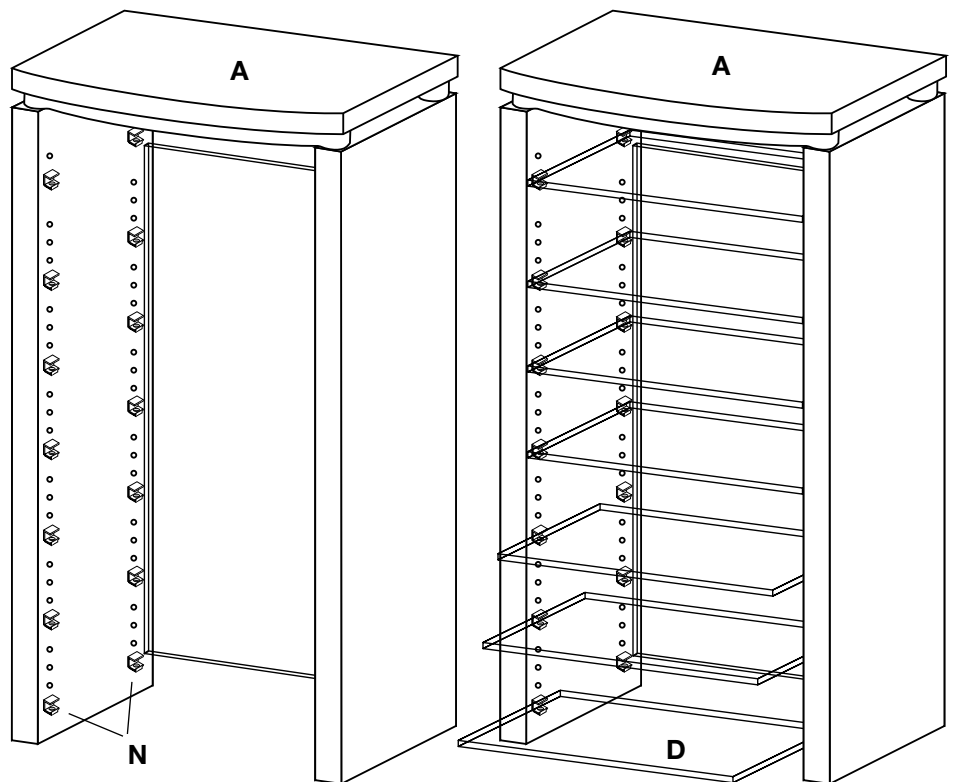

Congratulations and enjoy your new ELITE product!

**CLEANING Glass Surfaces and Matte Lacquer Surfaces (EL-479):** Apply window cleaner with soft. tissue. This will also eliminate slight surface abrasions or scratches that may have occurred in shipping or handling.  
**Wood Veneer Surfaces (EL-469) should only be cleaned with non-coloring or non-staining fine quality wood furniture polish.**

Distributed by: Elite Industries 77 Gould Street • Bayonne, NJ 07002

Elite Industries ensures complete satisfaction with this product. In the event of missing or damaged parts call toll free, **Customer service hours: 8:45-4:45, Monday-Friday, EST.**

1-800 ELITE-48 • Tel.: 201-436-1120 • Fax: 201-436-6960