

ASSEMBLY INSTRUCTIONS EL-461/EL-471

Audio Rack

EL-461 – Genuine Natural Cherry Wood Veneer.

EL-471 – Durable Metallic Grey Matte Lacquer.

Extra deep to accommodate high-end components. 4 levels, including 3 adjustable shelves.

Overall Dimensions: H - 48", W - 25.75" (Front), W - 22.25" (Rear), D - 23.5".

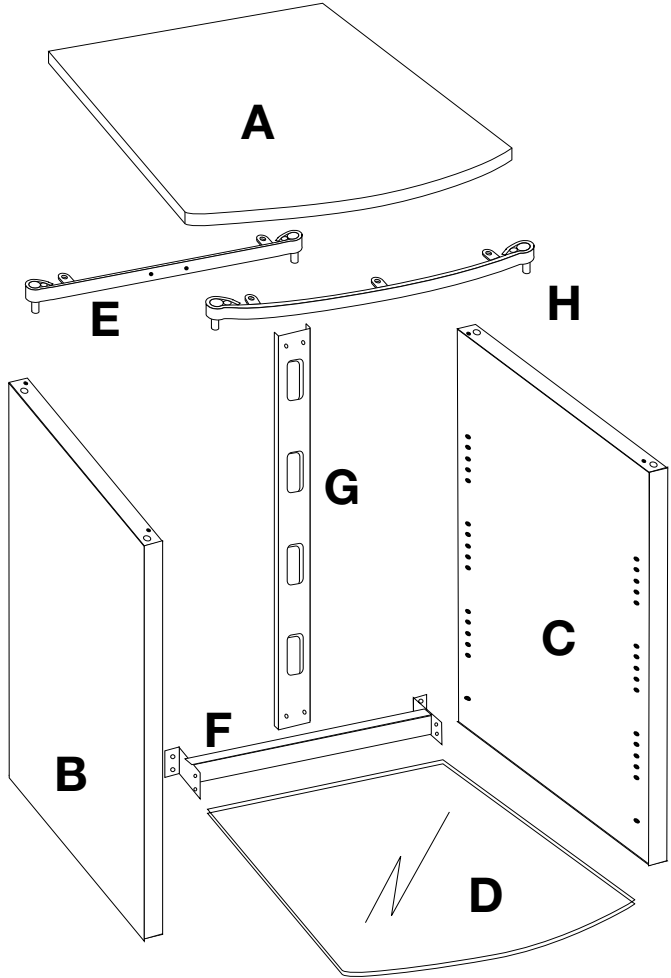

Thank you for purchasing this ELITE product. You will need the following tools:

- Regular straight blade screw driver
- Phillips head screwdriver
- Rubber or padded hammer

In order to protect the finish, we recommend working on a padded or carpeted surface.

Before discarding the box, be sure that no parts are left inside.

PLEASE NOTE: The following letters correspond to the sketches in this instruction booklet.

- A.** Top Panel (1)
- B.** Left Side Panel (1)*
- C.** Right Side Panel (1)*
- D.** Glass Shelf (4-identical)
- E.** Back Metal Top Molding (1)
- F.** Back Metal Bottom Rail (1)
- G.** Metal Wire Management (1)
- H.** Front Metal Molding (1)

***IMPORTANT:** Make sure shelf pin holes on Side Panels B & C face inside during assembly. FRONT EDGES of Side Panels B & C do NOT have holes at bottom. Curved Molding (Front Metal Molding - H) will be inserted into Front Edge of Side Panels B & C with metal tabs facing the back of unit. BACK EDGES of Side Panels B & C DO have holes at bottom for installation of Back Metal Bottom Rail (F). Straight Molding (Back Metal Top Molding - E) will be inserted into Back Edges of Side Panels B & C with metal tabs facing the back of the unit.

EL-461/EL-471 Hardware

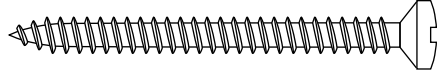
J  Screw - 3/16 x 1-7/8 - 4 pcs.

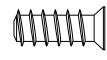
N  Screw - 1/4 x 3/8 - 2 pcs.

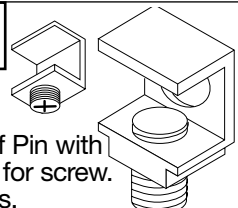
O  Shelf Pin with hole for screw. 2 pcs.

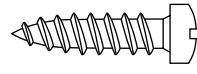
K  Screw - 5/32 x 13/16 - 5 pcs.

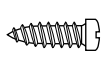
S  Screw - 1/8 x 3/8 - 2 pcs.

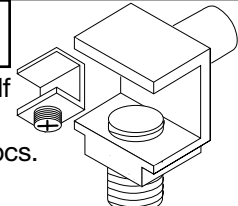
P  Shelf Pin 14 pcs.

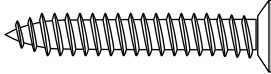
L  Screw - 5/32 x 1-3/16 - 8 pcs.

T  Strap for Wire Management (4)

M  Screw - 3/16 x 1/4 - 2 pcs.

U Adjustable Floor Levellers- 4 pcs. ALREADY FACTORY INSTALLED 

1 INSTALL FRONT & BACK MOLDINGS

IMPORTANT: Make sure shelf pin holes on Side Panels B & C face inside during assembly.

FRONT EDGES of Side Panels B & C **do NOT** have holes at bottom. Curved Molding (Front Metal Molding - H) will be inserted into Front Edge of Side Panels B & C with metal tabs facing the back of unit.

BACK EDGES of Side Panels B & C **DO** have holes at bottom for installation of Back Metal Bottom Rail (F). Straight Molding (Back Metal Top Molding - E) will be inserted into Back Edges of Side Panels B & C with metal tabs facing the back of the unit.

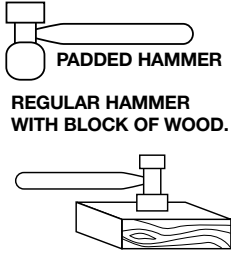

Use a padded hammer or a regular hammer with a block of wood when tapping moldings into place.

Tap left and right sides of moldings alternately to make sure that moldings are inserted evenly into both side panels. Do not fully tap in one side of molding before tapping in the opposite side. This may cause damage to side panels.

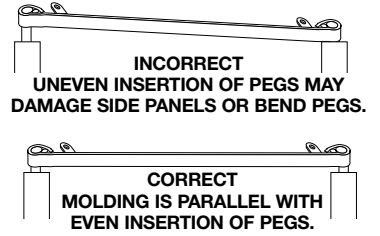

Install Front Molding (H) by slotting peg ends into holes provided on Right Side Panel (C) and Left Side Panel (B).

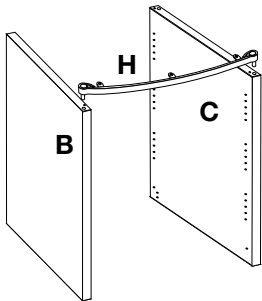

Tap right and left sides of molding alternately to insure even insertion of pegs.

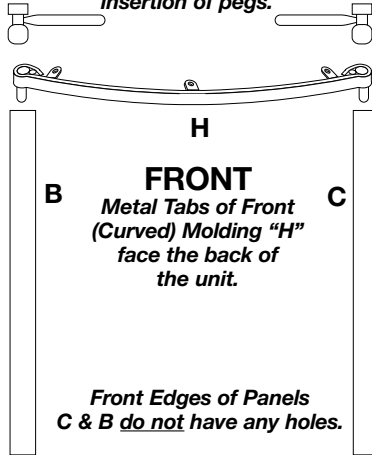

Tap right and left sides of molding alternately to insure even insertion of pegs.

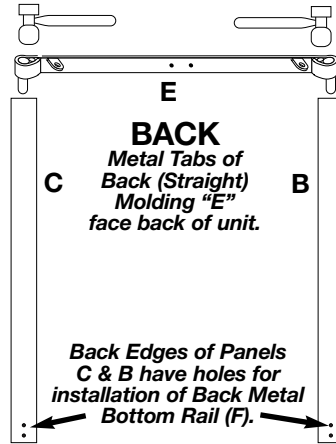

Install Back Top Molding (E) by slotting peg ends into holes provided on Right Side Panel (C) and Left Side Panel (B).

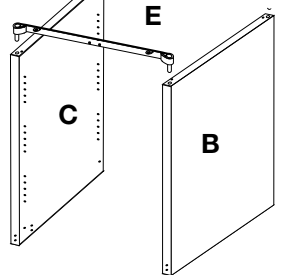

2 ATTACH BOTTOM METAL BACK RAIL

Using 8 screws (L) fix Bottom Rail (F) to Right Side Panel (C) and Left Side Panel (B).

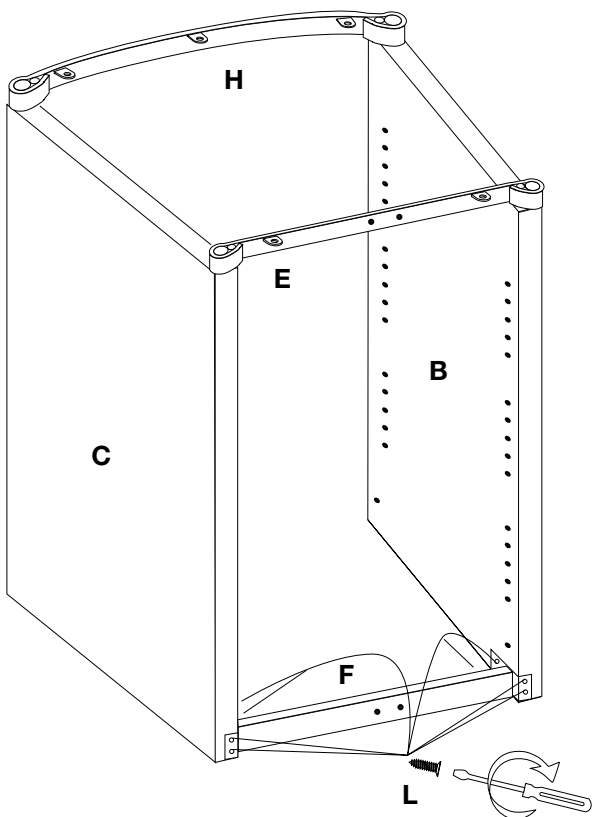

3 ADD SCREWS TO FRONT & BACK MOLDINGS

Using 4 screws (J) secure the Front Metal Molding (H) and the Top Metal Back Molding (E) to the side panels.

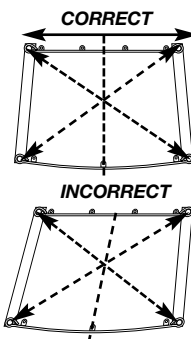

IMPORTANT! Be sure to maintain correct frame angle before fully tightening screws J. Check to make sure diagonal distance from corners is the same. Do not allow frame to shear side to side or front to back as this will alter alignment of holes of top A with molding holes.

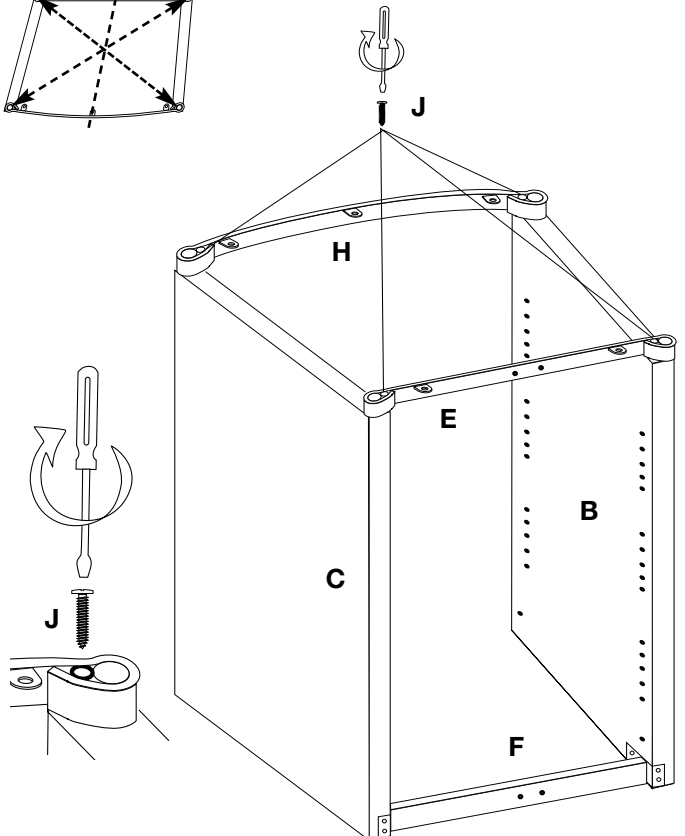

4 ATTACH THE TOP PANEL

Lay Top Panel (A) facedown on a padded surface, exposing the screw holes as shown.

Turn the frame completed through steps 1, 2, and 3 upside down and position metal molding slots over screw holes in top A.

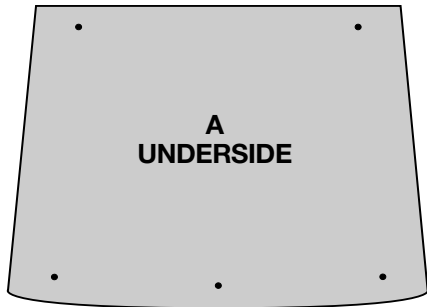

Using 5 screws (K) secure the Front Metal Molding (H) and the Top Metal Back Molding (E) to the Top Panel (A).

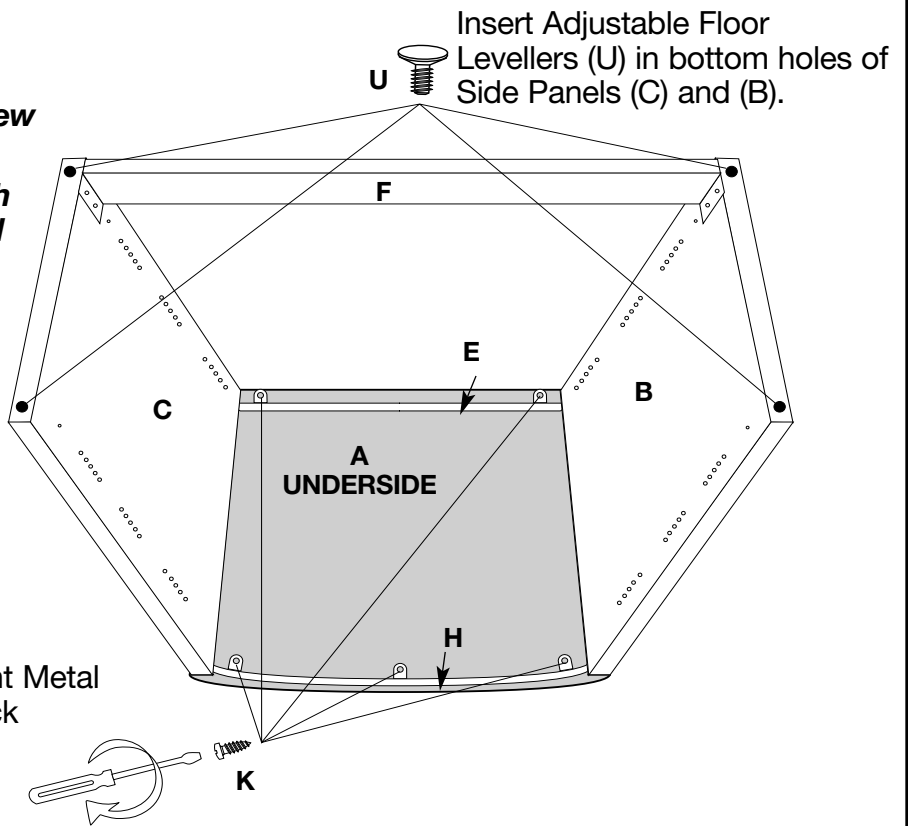

5 ATTACH METAL WIRE MANAGEMENT

Attach Metal Wire Management (G) to the Top Metal Back Molding (E) using 2 screws (M).

Attach Metal Wire Management (G) to the Bottom Metal Back Rail (F) using 2 screws (S).

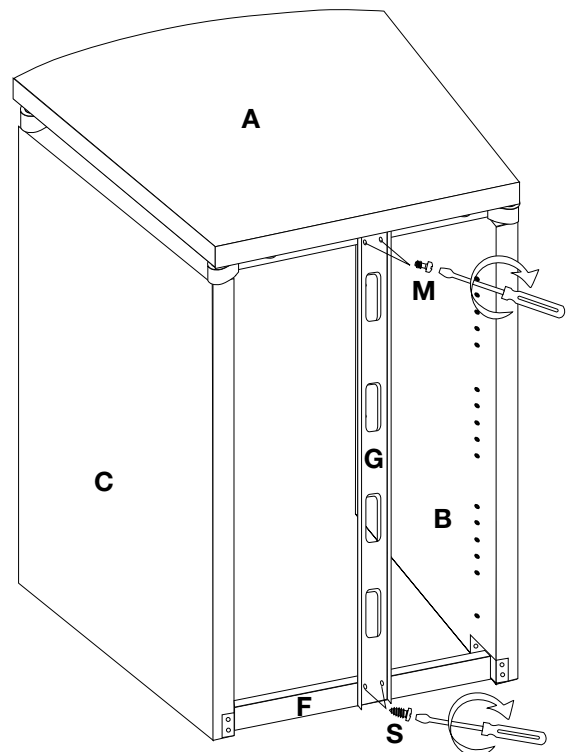

6 ADD SHELF PINS

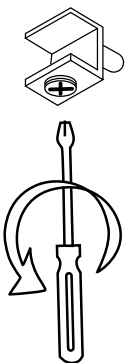

Before adding Shelf Pins (P) to lower level holes at the back of the unit, adjust the factory installed plastic screw to allow for the glass shelf thickness.

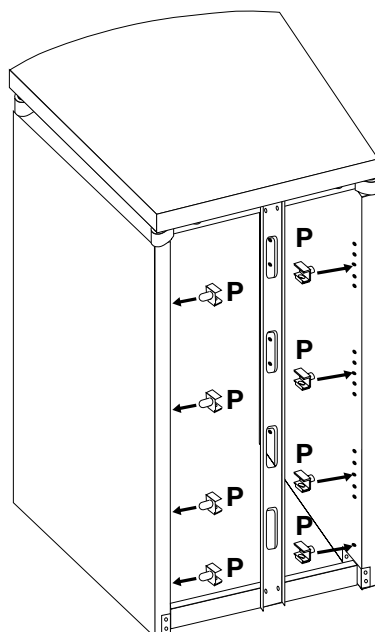

Insert 8 Shelf Pins (P) into back right and left side panels at desired location.

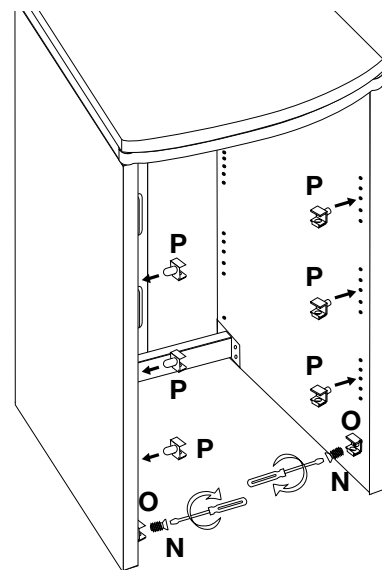

Attach 2 Shelf Pins (O) using screws (N) into bottom front holes on right and left side panels. Insert 6 Shelf Pins (P) into front right and left side panels at desired location.

7 ADD GLASS SHELVES

NOTE: Before adding glass shelves, check plastic screw adjustment on ALL shelf pins to be sure glass will slide smoothly into slots from front to back.

Slide bottom permanent glass shelf into shelf pins. Slide 3 adjustable glass shelves into shelf pins.

Carefully turn the plastic screw adjustment on the underside of the FRONT shelf pins to secure the glass in position. You may find it necessary to tilt the front end of the unit up to reach the bottom shelf pin screw adjustments.

Carefully turn the plastic screw adjustment on the underside of the BACK shelf pins to secure the glass in position.

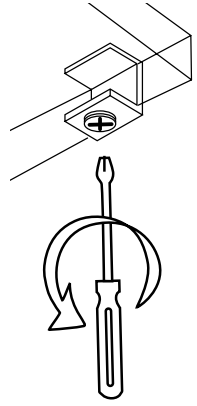

Adjust plastic screws on undersides of all shelf pins.

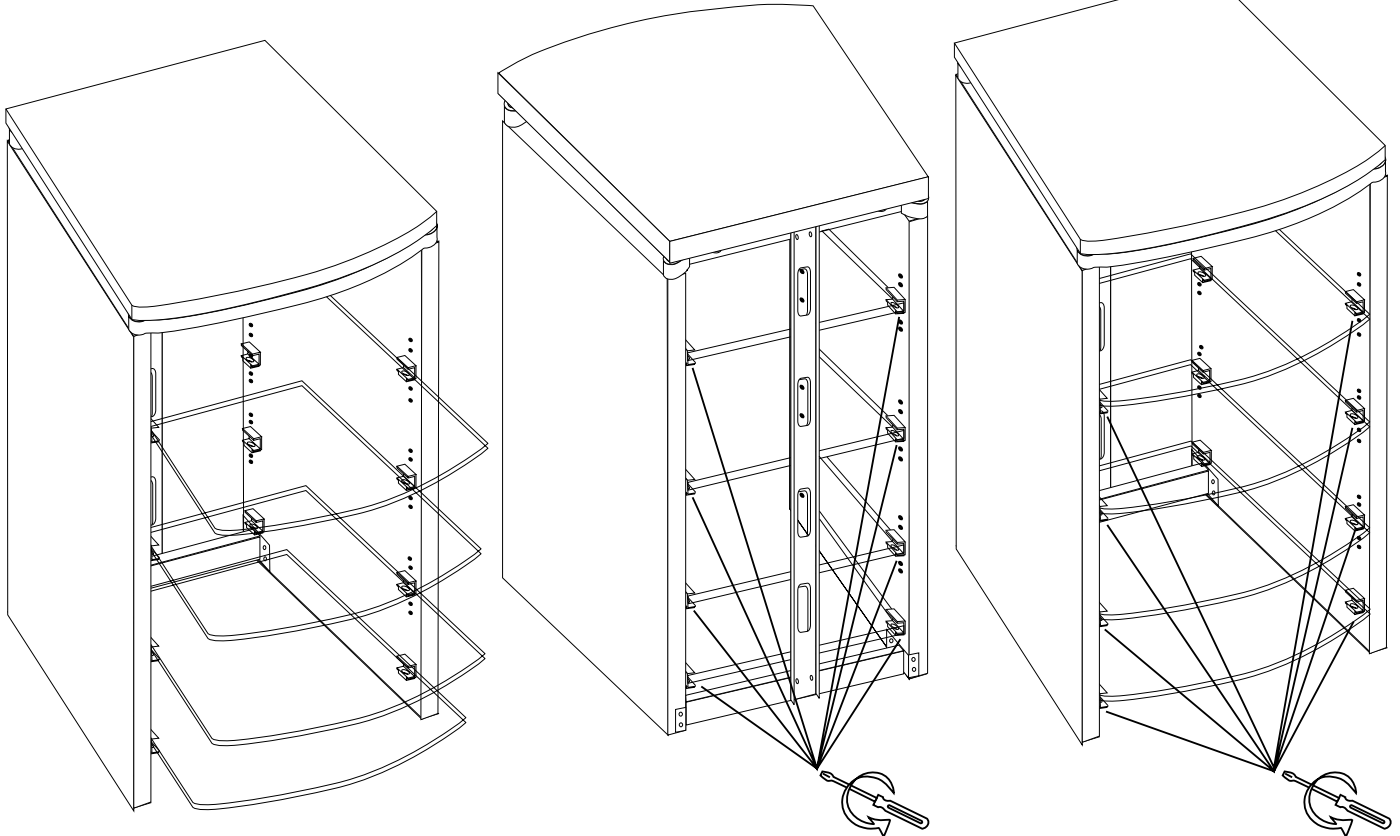

8 FINISHING TOUCHES

Use the Plastic Straps (T) to neatly secure wires that exit through the Metal Wire Management (G).

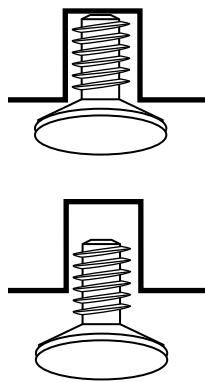
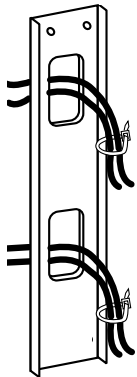

Adjustable floor-levelers are provided under your unit. Make sure to adjust unit so that it may firmly be positioned for support while staying parallel to ground. Avoid any forward tilt which may cause TV to lean off balance. Do not to over-extend levelers beyond their supporting housing. They need to firmly remain within the grip of their threaded bushings. Maximum extension = 1/4".

Congratulations and enjoy your new ELITE product!

CLEANING

Glass Surfaces and Matte Lacquer Surfaces (EL-471): Apply window cleaner with soft, tissue. This will also eliminate slight surface abrasions or scratches that may have occurred in shipping or handling.

Wood Veneer Surfaces (EL-461) should only be cleaned with non-coloring or non-staining fine quality wood furniture polish.

Distributed by: Elite Industries 77 Gould Street • Bayonne, NJ 07002

Elite Industries ensures complete satisfaction with this product. In the event of missing or damaged parts call toll free, **Customer service hours: 8:45-4:45, Monday-Friday, EST.**

1-800 ELITE-48

Tel.: 201-436-1120 • Fax: 201-436-6960